

Experiments for the Lab9500

Chapter 2 Lab9500 Board – Circuit Description

The complete schematic of the Lab9500 board can be found as a PDF file at this link:

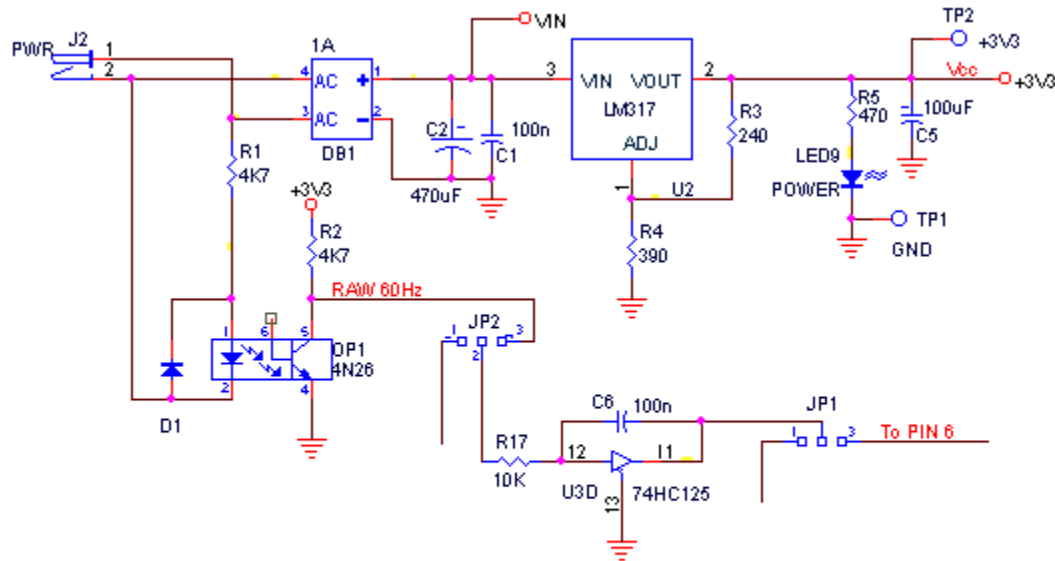

Figure 1 - Power Supply and 60Hz

The power supply and 60Hz generation of the Lab9500 is shown in Figure 1. Power to the board is applied via a wall transformer with a female power plug on it. The board has the corresponding mating make plug, J2. The board will take either an AC or DC wall transformer. However, in order to obtain a time-base from the 60 Hz line, an AC one has to be used. AC power is applied to opto-isolator OP1. The output of the isolator is applied via jumper JP2 to gate U3D. This circuit acts as a Schmitt trigger and provides a nicely squared 60 Hz signal. Jumper JP1 routes this to pin 6 of the XC9572XL.

When an AC wall transformer is used, full-wave diode bridge DB1 rectifies the AC and capacitors C1 and C2 smooth it out. When a DC wall transformer is used, the jumpers on

JP1 and JP2 are put in between pins 1 and 2, which permits pushbutton S3 to use gate U3D as a debouncer. In this case, U5, a PIC microcomputer, is used to provide the 60 Hz time base. Figure 2 shows the PIC. By putting jumpers JP1 and JP2 with the jumper to the left, the PIC output is connected to the 60 Hz input (Pin 6) on the XC9572XL, and the debouncer is used for S3 which can be seen on Pin 16. The PIC16C505 has a built-in, factory-trimmed 4 MHz oscillator. A suitable program can be written to generate a 60 Hz waveform at output RC2. The unused inputs can be used to select other frequencies. The board was designed to take the PIC16C505 (14-pin), but it will also taking the less-expensive 8-pin 12C509. The program checks to see which (if any) of ten (five) unused inputs is grounded. Grounding a single one of these can provide a choice of ten (five) additional frequencies. Grounding more than one pin could allow other choices. The chip itself generates a free-running cycle clock of 1 MHz. Among them could be 4Hz, 2Hz, 1KHz, 9.6KHz, etc. Input RB3 can be used as a reset input. Figure 2 shows the optional PIC time-base generator.

Provision has been made on the board for a +5 Volt supply that can be used off-board. One possible use is for the +5V supply for external solid-state relays. Note, even though the

XC9572XL family runs on +3.3 V, it can be used to sink opto-isolators connected to a +5 Volt supply. An output can be programmed to be active low, but tri-stated otherwise. This means that the floating output when not active low is able to tolerate +5 Volts. Figure 3 shows the optional +5 Volt supply. The parts are not stuffed.

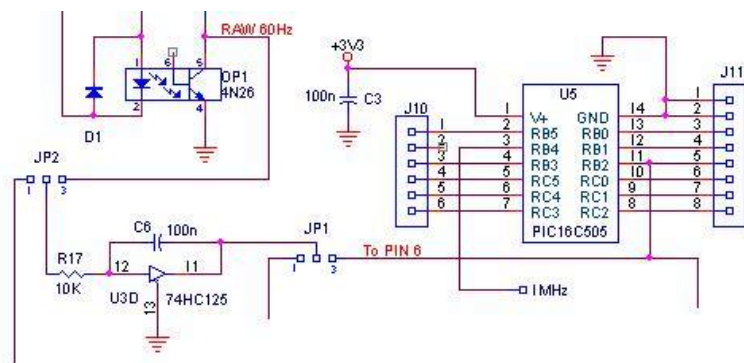

Figure 2 - PIC 60 Hz Timebase Generator

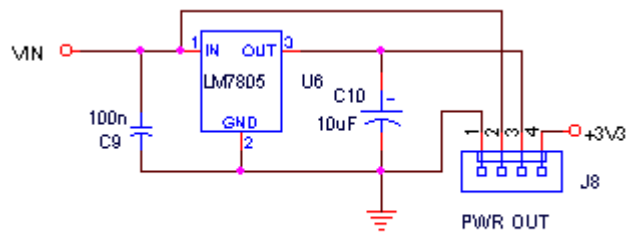

Figure 3 - Optional +5 Volt Supply

LAB9500 Inputs

The following complement of input devices is found on the board: three pushbuttons (S1, S2, S3), two of which are debounced; and a ten-position DIP switch, S4; a row of eight single-color LEDs, LED1 through LED8; and two sets of Red, Amber. All macrocell I/O pins are brought out to four dual-row headers which surround the XC9572XL chip. If female headers are installed for J3 through J6, then a daughter board could be plugged in that could use all of the I/O capability of the XC9572XL chip. For normal use, these headers are not installed, and the holes for the headers provide a very convenient place to

probe I/O voltages and also to test for continuity from the chip pins to chip I/O. (A separate drawing is provided to show the mapping of chip pins to header positions.)

Pushbutton switches S1 and S2 are debounced. They are convenient for providing slow, bounceless clock signals, for example, to exercise a counter. Switch S3 as already mentioned is not debounced if an AC wall transformer is used for the 60 Hz time-base. If the board uses the optional PIC for the time base, then S3 can use the debouncer assigned to the 60 Hz signal. In that case, the debounced input S3 comes in on Pin 16, otherwise, input S3 comes in on Pin 11.

The prototype version of the LAB9500 used an 8-position DIPswitch. A DIPswitch was used because it was inexpensive, and it did not take a lot of board space. Discrete switches would not only take a lot more board real estate, but add a lot to the cost of the board. On the other hand, it is nevertheless desirable to use discrete switches in lieu of the rather difficult to operate DIP switches. So the LAB9500 brings out the ten inputs of the DIP switches to an optional board edge mounted DB15 connector. This permits the instructor or the student to use external discrete switches instead of the DIP switches.

The prototype had an 8-position DIP switch. This seemed to be satisfactory in theory. But by adding two additional switch positions, the function of eight of the switches or the bank of eight LEDs can be selected by the additional two switches (four combinations).

The four unused pins on the DB15 connector can be used to bring in additional inputs (or outputs) or to parallel the on-board pushbuttons.

Figure 4 shows the inputs for the Lab9500.

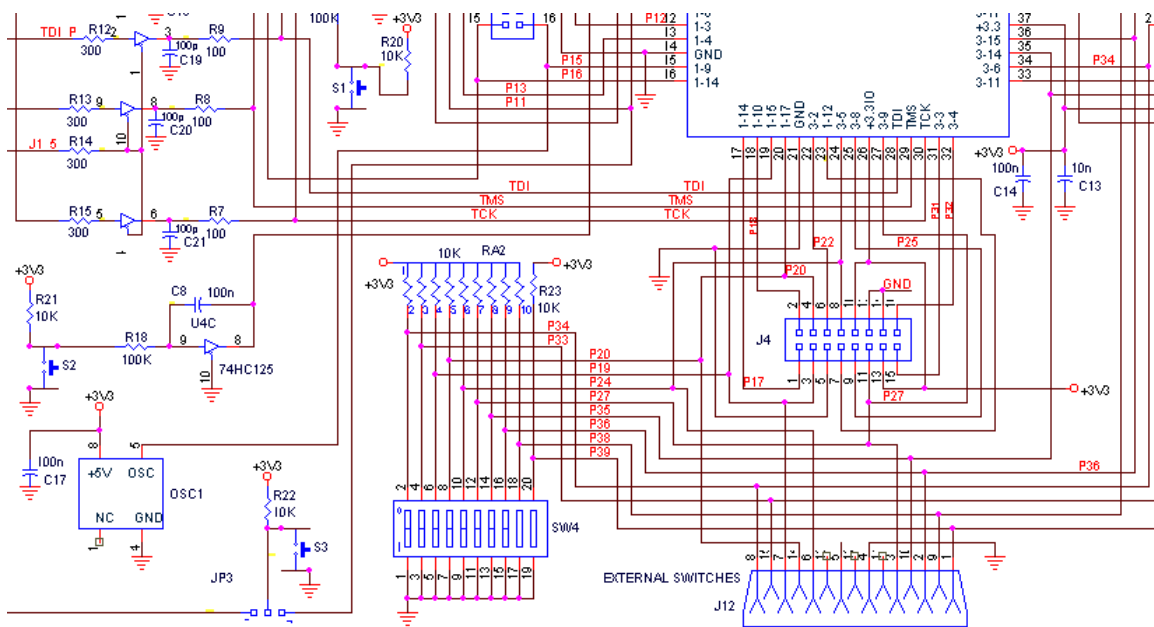

Figure 4 – LAB9500 Inputs

LAB9500 Outputs

The outputs on the LAB9500 consists of two sets of LEDs. One is a set of eight LEDs of a single color (color varies). The other is the six traffic light LEDs, two red, two amber and two green. The set of eight LEDs is useful for displaying intermediate results, especially for debug purposes. In a particular experiment, they may display one of several possibilities depending upon the state of the DIP switches.

The traffic light LEDs are suitable, of course, for representing a traffic light. However, they are equally useful for displaying six discrete outputs. Figure 5 shows the bank of eight LEDs. And Figure 6 shows the traffic light LEDs.

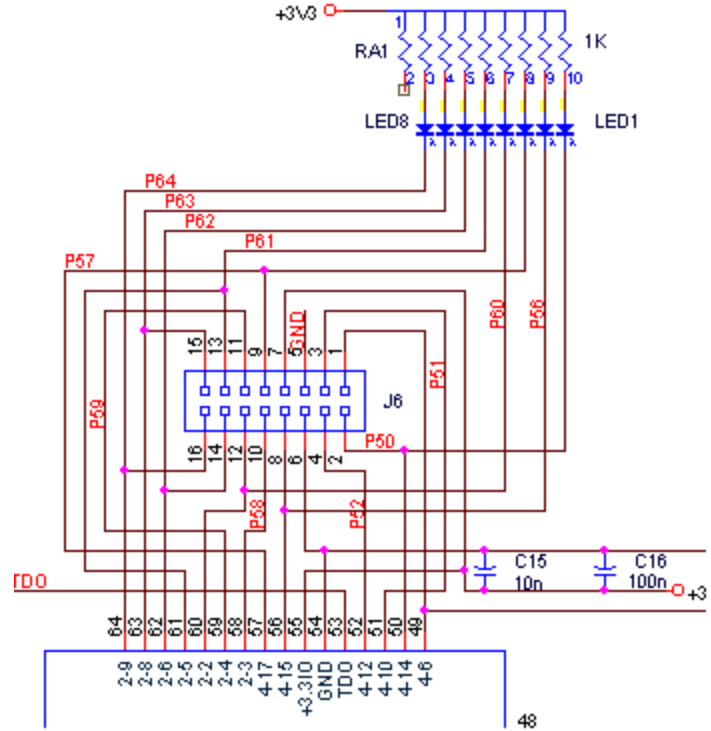

Figure 5 - Lab9500 Outputs - Bank of 8 LEDs

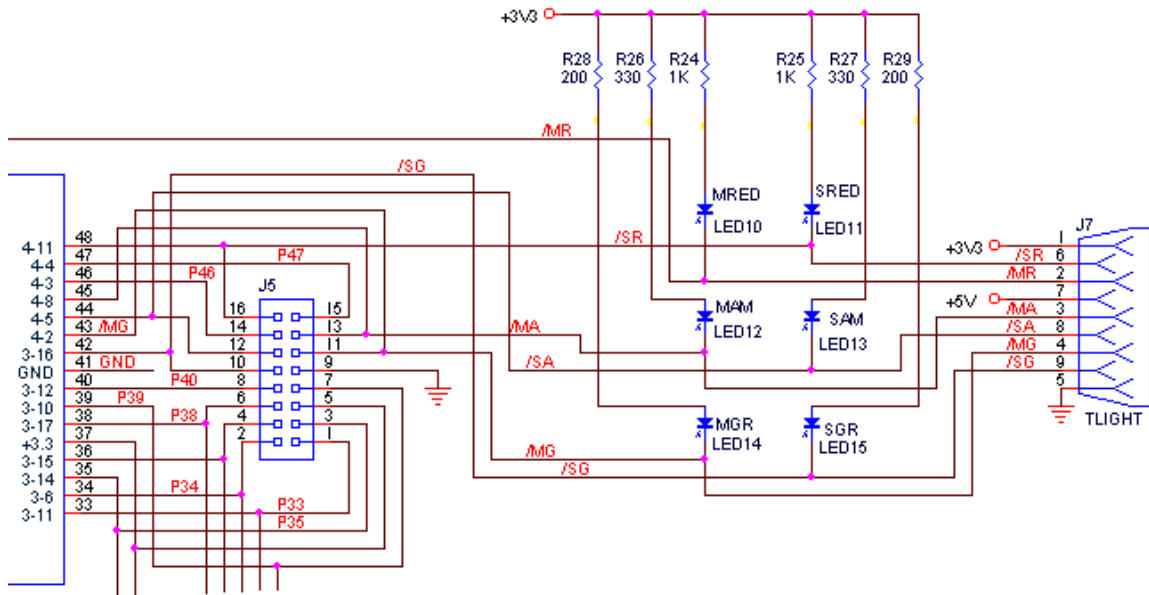

Figure 6 - Lab9500 Traffic Light LEDs

JTAG Programmer

The XC9572XL is programmed by a JTAG programmer interface. Typically, the JTAG programmer is a separate unit that attaches to the printer port of a PC on one side and to the target board on the other. However, (thanks to a suggestion by Clint Cole of Washington State University), the JTAG programmer interface is built into the DigiLab board. That saves the need for a separate programmer board, connectors and interface cable. Besides, the LAB9500 is intended to be used as a piece of lab equipment and will be continually re-programmed. The on-board programmer saves costs, minimizes connection problems and is more convenient. Figure 7 shows the JTAG interface.

The board connects directly to a printer port via connector J1, five gates of U3 and U4, together with resistors and capacitors, provide the interface circuitry. A DigiLab board could be partially populated to serve as a JTAG programmer. For this connector J10 would be installed, and the board could be used via J10 to program other boards containing 9500 family devices that have no programmer built in.

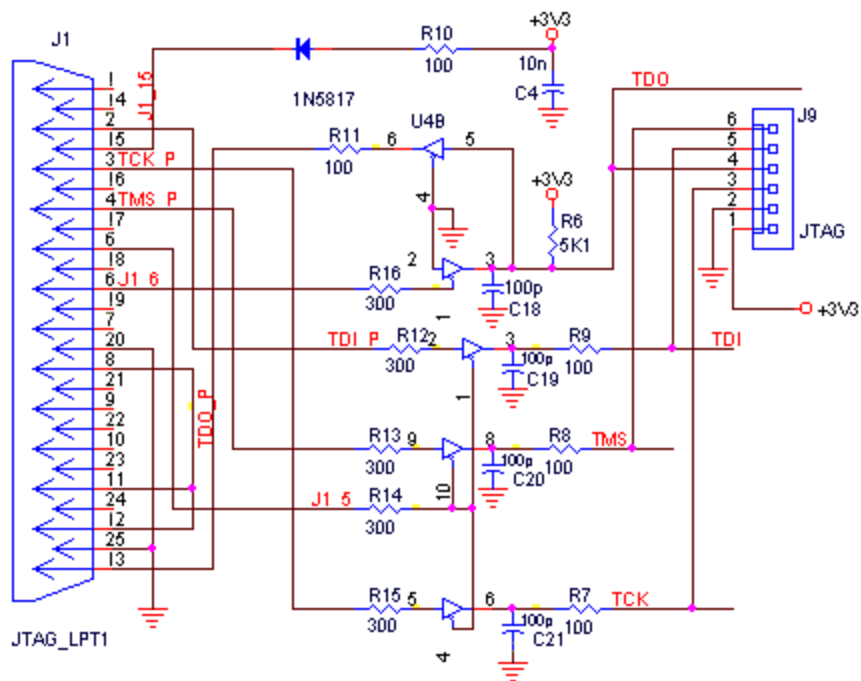

Figure 7 - JTAG Programmer

Expansion

The XC9572XL has 72 macrocells, but uses a 64-pin package. Some pins are used for power and some pins are used for the JTAG interface, leaving 52 of the 72 pins accessible for I/O. Since a complex design will generally have internal counters,

registers, logic nodes, etc. this is probably more pins than actually can be used in a complex design. In other words, there is no need or advantage to having all macrocells externally available. A Significant number of the available pins are used for the built-in I/O functions: 13 switch bits, 14 LEDs and the 60 Hz signal. This leaves approximately 24 uncommitted I/O pins. Since many of the macrocells which these represent will be needed for internal functions, it is unlikely that as many as 24 I/O pins are really available. Nevertheless, for maximum flexibility, every chip pin, including those already connected to on-board I/O, are brought out to four dual-row headers which surround the chip. Either male or female headers may be soldered into the header footprints. (Installed headers do not come with the board). The assignment of chip pins to header pins is shown in Figure 8. that follows.

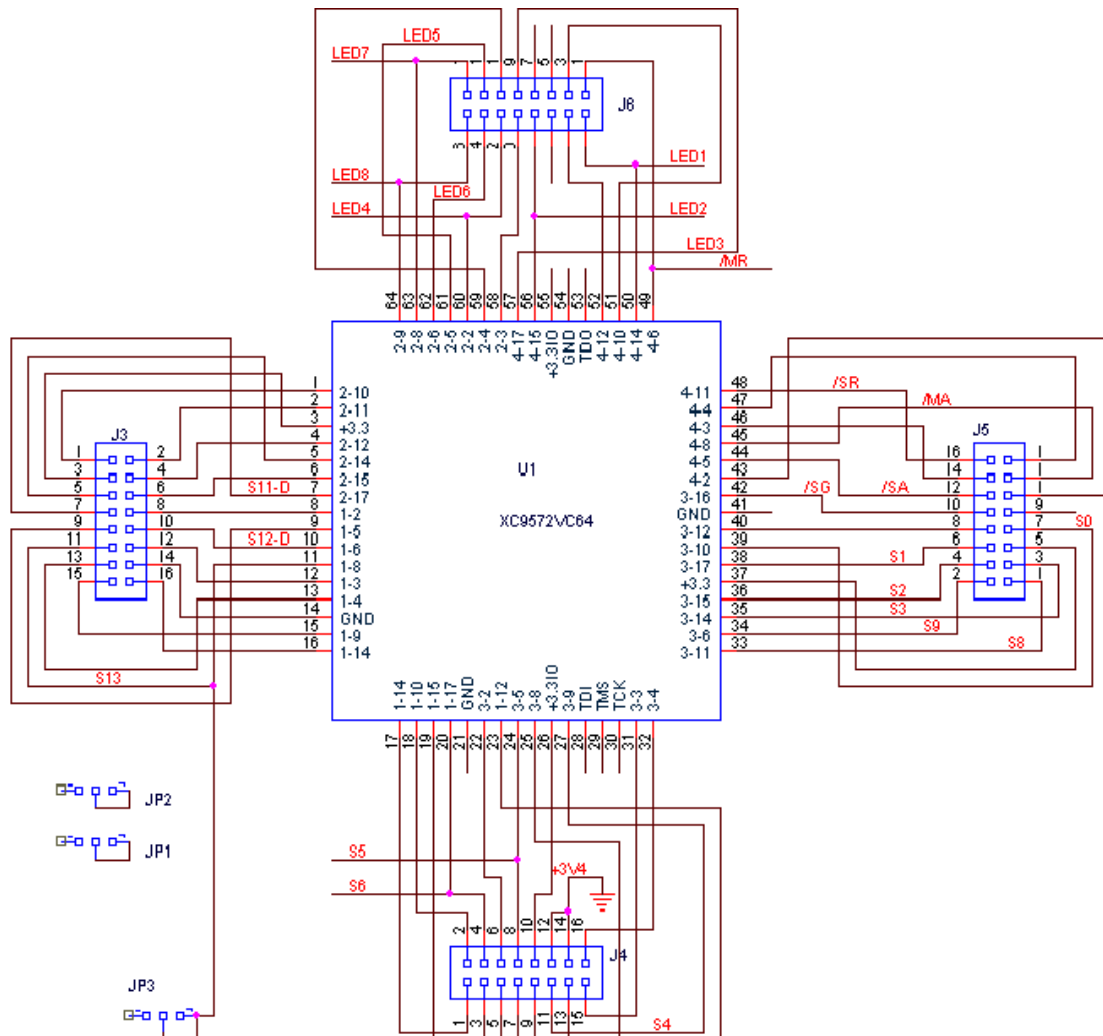

Figure 8. Expansion Headers for the XC9572XL

You will notice in Figure 8 that there is a different switch numbering. The prototype of the Lab9500 board had an 8-position DIP switch, S4. The three pushbuttons were S1 through S3. Now, the DIP switch is ten positions. Since they are often used as a byte of input or as two nibbles, they are called for experimentation purposes S0 through S9 with

S0-S3 being the lower nibble, S4-S7 the high nibble, and S8 and S9 extra switches. The pushbuttons S1-S3 are called for experimentation S11-S13. Also for experimentation purposes, it is probably preferable to call the bank of LEDs L0 through L7 instead of L1 through L8.